

ANSTY GARDEN COMMUNITY,

WEST SUSSEX

DESIGNERS RESPONSE

REPORT REF NO. 2207280-R14

PROJECT NO. 2207280

OCTOBER 2023

Head Office: Third Floor, The Hallmark Building, 52-56 Leadenhall Street, London EC3M 5JE | 020 7680 4088

Edinburgh: Suite 35, 4-5 Lochside Way, Edinburgh EH12 9DT | 0131 516 8111

Essex: 1-2 Crescent Court, High Street, Billericay CM12 9AQ | 01277 657677

Kent: Suite 10, 40 Churchill Business Square, Kings Hill, West Malling, Kent ME19 4YU | 01732 752155

Midlands: Office 3, The Garage Studios, 41-43 St Mary's Gate, The Lace Market, Nottingham NG1 1PU | 0115 697 0940

South West: Temple Studios, Temple Gate, Bristol BS1 6QA | 0117 456 4994

Suffolk: Suffolk Enterprise Centre, Felaw Maltings, 44 Felaw Street, Ipswich IP2 8SJ | 01473 407321

Contents

	Page
1.0 INTRODUCTION	2
2.0 AUDIT RESPONSE TO STAGE 1 ROAD SAFETY AUDIT	3

APPENDICES

- A. Stage 1 Road Safety Audit**
- B. M&S Response to draft Designers Response**
- C. ARCADY Output**

Document Control Sheet

REV	ISSUE PURPOSE	AUTHOR	CHECKED	APPROVED	DATE
-	Draft for M&S Approval	DV	DH/KK	Draft	19/10/2023
-	Draft for M&S Approval	DV	DH/KK	Draft	24/10/2023
-	Final for Submission to WSCC	DV	JS/KK <i>JS</i>	DH <i>DH</i>	26/10/2023

K. W. Kay

Distribution

This report has been prepared for the exclusive use of Fairfax Acquisitions Ltd. It should not be reproduced in whole or in part, or relied upon by third parties, without the express written authority of Ardent Consulting Engineers.

1.0 INTRODUCTION

- 1.1 Ardent Consulting Engineers (ACE) has been appointed by Fairfax Acquisitions Ltd to advise on the transport aspects of the proposed development at Land Adjoining Ansty, West Sussex.
- 1.2 The proposed development comprises a residential-led, mixed-use development comprising up to 1,450 homes, a local centre, two schools and other community uses such as sports pitches.
- 1.3 This report addresses matters originally raised in the Stage 1 Road Safety Audit (RSA) undertaken by M & S Traffic (M&S), dated October 2023. The Audit is attached at **Appendix A**.
- 1.4 The Audit was undertaken on the proposed A272 Western Access roundabout junction, which is located on the western boundary of the proposed development site. The works involve the construction of a new roundabout and pedestrian/cycle infrastructure improvements to include new crossing facilities.
- 1.5 In advance of submission of this Designers' Response to WSCC as the overseeing organisation, a draft was issued to M&S in order to seek their feedback on the proposed responses and obtain their in-principle approval. The responses incorporated within this Designers Response incorporate M&S recommendations/acceptance as attached at **Appendix B**.
- 1.6 The following drawing have been prepared to incorporate the findings of the RSA:
- **ACE Drawing 2207280-004D** – Proposed Roundabout Western Access (A272)

2.0 DESIGNERS RESPONSE TO STAGE 1 ROAD SAFETY AUDIT

Table 2.1 Project Details

Report title:	Designers Response to Stage 1 Road Safety Audit – Western Access
Date:	October 2023
Document reference and revision:	2207280-R14
Prepared by:	Ardent Consulting Engineers
On behalf of:	Fairfax Acquisitions Ltd

Table 2.2 Authorisation Sheet

Project:	Ansty Garden Community
Report title:	Designers Response to Stage 1 Road Safety Audit – Western Access
Prepared by	
Name:	Dan Vallance
Position:	Principal Transport Planner
Signed:	<i>DV</i>
Organisation:	Ardent Consulting Engineers
Date:	26/10/2023
Approved by	
Name:	David Howson
Position:	Associate
Signed:	<i>DH</i>
Organisation:	Ardent Consulting Engineers
Date:	26/10/2023

Table 2.3 Key Personnel

Overseeing Organisation:	WSCC Highways– Mr G. Parfect
RSA team:	M&S - Mr B. Shawyer & Mr M. Morris
Design organisation:	Ardent – Mr D. Vallance, Mr D. Howson & Mr K. Markey

Table 2.4 Road Safety Audit Decision Log

RSA problem	RSA recommendation	Design Organisation response	Overseeing Organisation response	Agreed RSA action
<p>3.1.1 Insufficient construction details could lead to overshoot or rear end shunt collisions.</p> <p>The proposals do not include the introduction of anti-skid surfacing or detail the Polished Stone Value (PSV) to be used on the approaches to the roundabout and surfacing as part of the scheme. Surfacing with an insufficient PSV could lead to overshoot or rear end shunt collisions.</p>	<p>It is recommended that high friction surfacing should be provided on all the approaches to the roundabout and that the PSV of all surfacing should be provided for assessment.</p>	<p>Details of PSV values and surfacing materials will be provided for Stage 2 Audit.</p>		
<p>3.1.2 Ponding of surface water could lead to loss of control collisions.</p> <p>Kerblines are being amended as part of these proposals, where no details of</p>	<p>It is recommended that drainage details should be provided at Stage 2 Safety Audit.</p>	<p>Drainage details will be provided for Stage 2 Audit.</p>		

<p>carriageway drainage have been provided for assessment; ponding on the carriageway or water moving across the carriageway at junctions or bends could lead to loss of control collisions, particularly in wet / icy conditions.</p>				
<p>3.2.1 Approaches to the proposed roundabout.</p> <p>Stopping Sight Distances (SSD) have been provided for assessment and at 215m are acceptable for the current national speed limit. An insufficient SSD may increase the risk of junction related or shunt type collisions at the roundabout and so the 120m SSD, which is commensurate with a 40mph design speed, should only be incorporated if a reduced speed limit of 40mph is introduced.</p>	<p>It is recommended that the SSD should be commensurate with the design speeds.</p>	<p>The proposed roundabout will significantly change the nature of speeds approaching the proposed crossing location, resulting in lower than compared to the current speeds</p> <p>Visibility splays for the current posted speed has been shown and noted to be kept clear to be robust at this stage.</p> <p>A change in speed limit is at the discretion of WSCC but agreed, if there is a change, the splays provided will be in accordance with speed limit.</p> <p>As presented on ACE Drawing 2207280-004D, the design incorporates suitable visibility splays based on the current posted speed limit.</p>		

<p>3.2.2 Insufficient Stopping Sight Distance may increase the risk of junction related or shunt type collisions at the roundabout.</p> <p>On the southwest bound approach to the roundabout SSDs have been provided for assessment. However, there is concern that the SSDs pass over non-highway land. Vegetation or landscaping features in these splays could restrict visibility, where insufficient visibility may increase the risk of junction related or shunt type collisions at the roundabout.</p>	<p>It is recommended that a suitable covenant should be arranged to ensure that the splay is not affected by planting or landscaping features.</p>	<p>All visibility splays are within highway land or land within the development site and therefore can be kept clear as shown and noted on ACE Drawing 2207280-004D.</p>		
<p>3.2.3 Insufficient Stopping Sight Distance may increase the risk of junction related or shunt type collisions at the roundabout.</p> <p>On the approach to the roundabout no SSD has been provided for assessment. There is concern that the SSD could pass over non-highway land. Vegetation or landscaping features in this splay could restrict visibility, where insufficient visibility may increase the risk of junction related or shunt type collisions at the roundabout.</p>	<p>It is recommended that the SSD should be supplied for assessment and that they should be within the adoptable highway, or that a suitable covenant should be arranged to ensure that the splay is not affected by planting or landscaping features.</p>	<p>The development arm of the roundabout will be subject to a 20/30mph speed limit. All visibility splays are within highway land or land within the development site and therefore can be kept clear as shown and noted on ACE Drawing 2207280-004D.</p>		

<p>3.2.4 Lack of vertical profile information could lead to side impact collisions or loss of control collisions.</p> <p>The proposed roundabout is located on the A272, where there is a fall from the southwest to the northeast. At this early stage no vertical alignment details were provided for assessment. There is concern that inappropriate vertical profiles could restrict visibility at the junction, which may lead to side impact collisions or loss of control collisions.</p>	<p>It is recommended that vertical alignment details should be provided for assessment at Stage 2 Safety Audit.</p>	<p>Details of vertical alignments will be provided for Stage 2 Audit.</p>		
<p>3.2.5 The exit layouts from the roundabout increase the risk of side swipe collisions, rear end shunts or loss of control collisions.</p> <p>On all arms, the proposed exits from the roundabout are two lanes wide, narrowing to one lane over a short merge length. The layout encourages aggressive drivers to overtake a slower moving vehicle over a relatively short distance. There is concern that such overtaking manoeuvres could lead to side swipe collisions, rear end shunts or loss of</p>	<p>It is recommended that the exits from the roundabout should be restricted to one wide lane.</p>	<p>The exits have been reduced and two marked lanes are no longer proposed. The comment is accepted and drawing updated as set out on ACE Drawing 2207280-004D.</p> <p>The exit widths are in accordance with CD116 Para 3.28.2 <i>'At a normal roundabout, if the downstream link is a single carriageway road, the exit width should be between 7 metres and 7.5 metres and the exit should taper down to a minimum of 6 metres. NOTE The</i></p>		

<p>control collisions, particularly as one of the of the merges is on a bend.</p>		<p><i>additional width allows traffic to pass a broken down vehicle.'</i></p> <p>The amended design accords with DMRB requirements as shown on ACE Drawing 2207280-004D.</p>		
<p>3.3.1 Insufficient capacity could lead to rear end shunt or side impact collisions.</p> <p>No details of expected flows and the capacity of the roundabout have been provided for assessment. Insufficient capacity could lead to congestion where excessive queuing at the roundabout could lead to driver frustration and the use of inappropriate gaps, further unbalanced flows could lead to entry problems on to the roundabout. This may lead to rear end shunt or side impact collisions.</p>	<p>It is recommended that the roundabout should operate without excessive queuing and with balanced flows and that an ARCADY or similar model should be provided for assessment.</p>	<p>An ARCADY assessment has been undertaken and demonstrates that the junction operates with spare capacity in the Development Case scenario. The results are attached at Appendix C.</p>		

<p>3.3.2 Low angle of entry may increase the risk of side impact collisions.</p> <p>The angle of entry was provided for assessment, where for northeastern and development arms the angle of entry was less than twenty degrees. Low angles of entry could force drivers to look over their shoulders or use their mirrors to merge with circulating traffic, increasing the risk of side impact collisions.</p>	<p>It is recommended that the angle of entry should lie between 20o and 60o.</p>	<p>Conflict angles have been re-calculated in accordance with CD116 Para 3.18.1. The geometry table has been updated as shown on ACE Drawing 2207280-004D.</p>		
<p>3.5.1 Insufficient street lighting could lead to loss of control collisions and side impact collisions during the hours of darkness.</p> <p>At this early stage no details of street lighting have been provided for assessment. A lack of lighting could increase the risk of loss of control and side impact collisions at the roundabout during the hours of darkness.</p>	<p>It is recommended that street lighting should be checked with the Highway Authority’s street lighting team and that a plan showing the light distribution should be provided for assessment at Stage 2 Safety Audit.</p>	<p>It has been noted on ACE Drawing 2207280-004D that street lighting is to be considered in liaison with WSCC as per the recommendation. Lighting details to be provided for Stage 2 Audit.</p>		

Table 2.6 Design Organisation Statement

On behalf of the design organisation I certify that:	
1) the RSA actions identified in response to the road safety audit problems in this road safety audit have been discussed and agreed with the Overseeing Organisation.	
Name:	David Howson
Signed	
Position:	Associate
Organisation:	Ardent Consulting Engineers
Date:	

Table 2.6 Overseeing Organisation Statement

On behalf of the Overseeing Organisation I certify that:	
1) the RSA actions identified in response to the road safety audit problems in this road safety audit have been discussed and agreed with the design organisation; and	
2) the agreed RSA actions will be progressed.	
Name:	Guy Parfect
Signed:	
Position:	Senior Planner
Organisation:	West Sussex County Council Highways
Date:	

Designers Response

Drawings

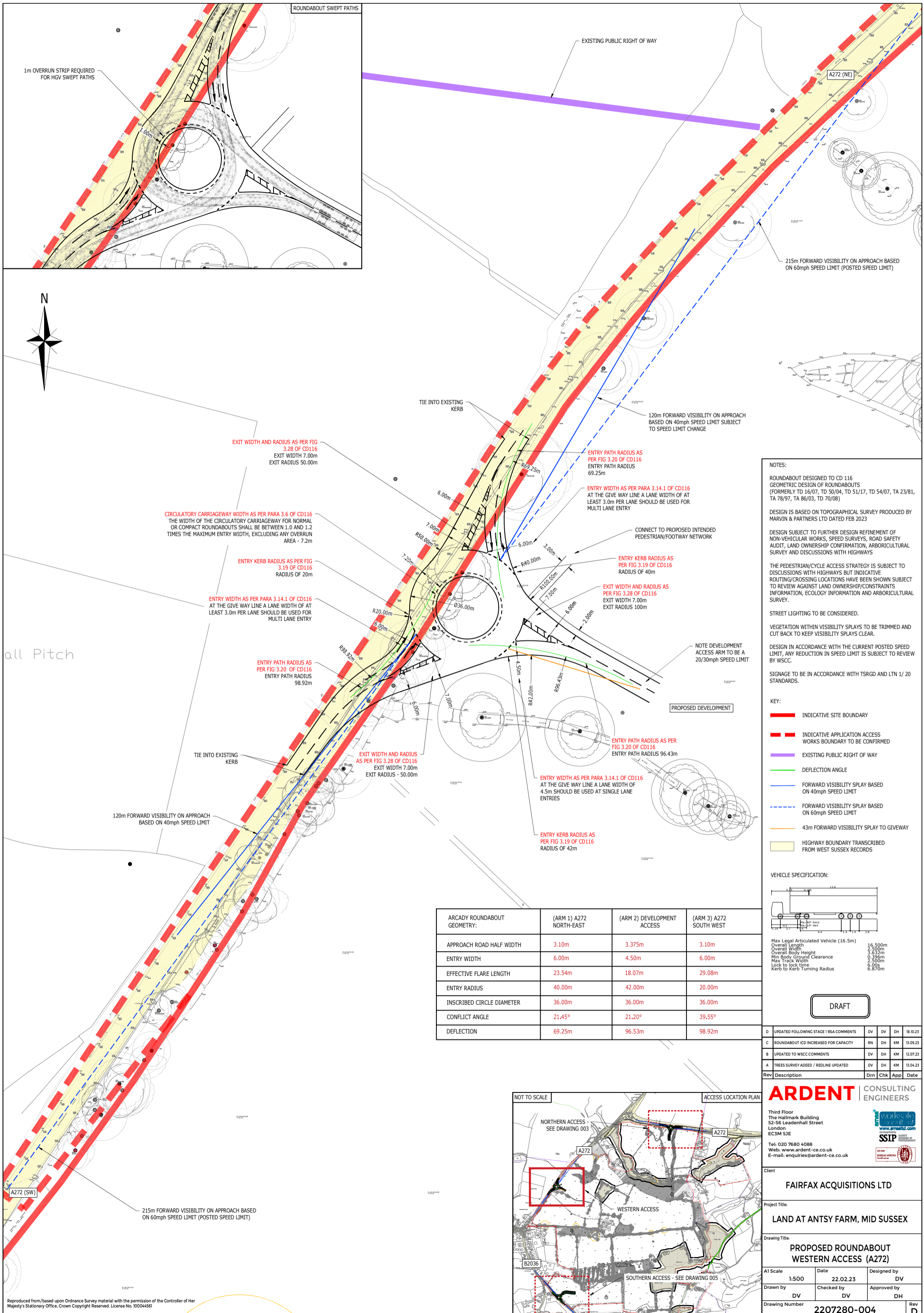

all Pitch

NOTES:

ROUNDABOUT DESIGNED TO CD 116
 GEOMETRIC DESIGN OF ROUNDABOUTS
 (FORMERLY TD 16/07, TD 50/04, TD 51/17, TD 54/07, TA 23/81, TA 78/97, TA 86/03, TD 70/08)

DESIGN IS BASED ON TOPOGRAPHICAL SURVEY PRODUCED BY MARVIN & PARTNERS LTD DATED FEB 2023

DESIGN SUBJECT TO FURTHER DESIGN REFINEMENT OF NON-VEHICULAR WORKS, SPEED SURVEYS, ROAD SAFETY AUDIT, LAND OWNERSHIP CONFIRMATION, ARBORICULTURAL SURVEY AND DISCUSSIONS WITH HIGHWAYS

THE PEDESTRIAN/CYCLE ACCESS STRATEGY IS SUBJECT TO DISCUSSIONS WITH HIGHWAYS BUT INDICATIVE ROUTING/CROSSING LOCATIONS HAVE BEEN SHOWN SUBJECT TO REVIEW AGAINST LAND OWNERSHIP/CONSTRAINTS INFORMATION, ECOLOGY INFORMATION AND ARBORICULTURAL SURVEY.

STREET LIGHTING TO BE CONSIDERED.

VEGETATION WITHIN VISIBILITY SPLAYS TO BE TRIMMED AND CUT BACK TO KEEP VISIBILITY SPLAYS CLEAR.

DESIGN IN ACCORDANCE WITH THE CURRENT POSTED SPEED LIMIT, ANY REDUCTION IN SPEED LIMIT IS SUBJECT TO REVIEW BY WSCC.

SIGNAGE TO BE IN ACCORDANCE WITH TSRGD AND LTN 1/20 STANDARDS.

- KEY:**
- INDICATIVE SITE BOUNDARY
 - INDICATIVE APPLICATION ACCESS WORKS BOUNDARY TO BE CONFIRMED
 - EXISTING PUBLIC RIGHT OF WAY
 - DEFLECTION ANGLE
 - FORWARD VISIBILITY SPYLAZ BASED ON 40mph SPEED LIMIT
 - FORWARD VISIBILITY SPYLAZ BASED ON 60mph SPEED LIMIT
 - 43m FORWARD VISIBILITY SPYLAZ TO GIVEWAY
 - HIGHWAY BOUNDARY TRANSCRIBED FROM WEST SUSSEX RECORDS

VEHICLE SPECIFICATION:

Max Legal Articulated Vehicle (16.5m)	16.500m
Overall Length	2.500m
Overall Width	3.532m
Overall Body Height	0.395m
Min Body Ground Clearance	2.500m
Max Track Width	6.876m
Lock to lock time	6.876m
Kerb to Kerb Turning Radius	6.876m

ARCADY ROUNDABOUT GEOMETRY:	(ARM 1) A272 NORTH-EAST	(ARM 2) DEVELOPMENT ACCESS	(ARM 3) A272 SOUTH WEST
APPROACH ROAD HALF WIDTH	3.10m	3.375m	3.10m
ENTRY WIDTH	6.00m	4.50m	6.00m
EFFECTIVE FLARE LENGTH	23.54m	18.07m	29.08m
ENTRY RADIUS	40.00m	42.00m	20.00m
INSCRIBED CIRCLE DIAMETER	36.00m	36.00m	36.00m
CONFLICT ANGLE	21.45°	21.20°	39.55°
DEFLECTION	69.25m	96.53m	98.92m

DRAFT

Rev	Description	Drm	Chk	App	Date
D	UPDATED FOLLOWING STAGE 1 RSA COMMENTS	DV	DV	DH	18.10.23
C	ROUNDABOUT ICD INCREASED FOR CAPACITY	RN	DH	KM	13.09.23
B	UPDATED TO WSCC COMMENTS	DV	DH	KM	12.07.23
A	TREES SURVEY ADEED / REDLINE UPDATED	DV	DH	KM	13.04.23

ARDENT CONSULTING ENGINEERS

Third Floor
 The Halmark Building
 52-56 Leadenhall Street
 London
 EC3M 5JE

Tel: 020 7680 4088
 Web: www.ardent-ce.co.uk
 E-mail: enquiries@ardent-ce.co.uk

Client: **FAIRFAX ACQUISITIONS LTD**

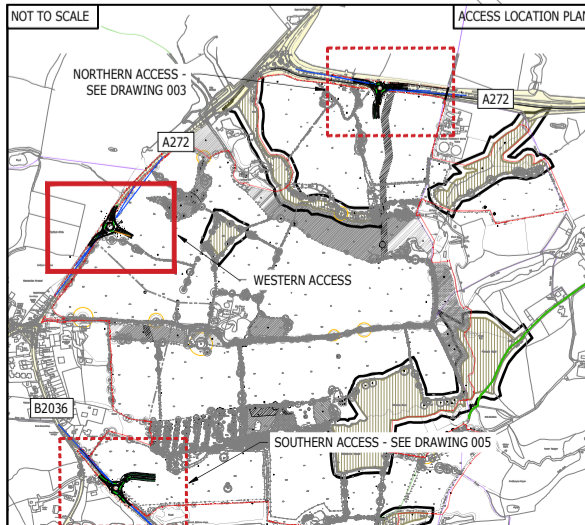

Project Title: **LAND AT ANTSY FARM, MID SUSSEX**

Drawing Title: **PROPOSED ROUNDABOUT WESTERN ACCESS (A272)**

A1 Scale	Date	Designed by
1:500	22.02.23	DV
Drawn by	Checked by	Approved by
DV	DV	DH

Drawing Number: **2207280-004**

Reproduced from/based upon Ordnance Survey material with the permission of the Controller of Her Majesty's Stationary Office, Crown Copyright Reserved. License No. 100044561

Designers Response Appendix A

Stage 1 Road Safety Audit



M & S Traffic

Road Safety Audit Stage 1

Land at Ansty Farm

Proposed Roundabout A272

Western Access

West Sussex

Date: 13th October 2023

Report produced for: Ardent Consulting Engineers

Report produced by: M & S Traffic Ltd

Registered Office: 32 Hamelin Road, Gillingham, Kent ME7 3EX Registered in Cardiff No:06730905

DOCUMENT CONTROL SHEET

M&S Traffic has prepared this report in accordance with the instructions from Ardent Consulting Engineers. M&S Traffic shall not be liable for the use of any information contained herein for any purpose other than the sole and specific use for which it was prepared.

Report Title:	Land at Antsy Farm, Mid Sussex (Proposed Roundabout Western Access – A272) Road Safety Audit Stage 1
Date:	13 th October 2023
Document reference and revision:	ARD/23//2207280/1/MM
Prepared by:	M & S Traffic
On behalf of:	West Sussex County Council

	Prepared by: (Name)	Checked by: (Name)	Approved by (Signature)	Date Approved
Revision	Martin Morris	Bryan Shawyer		13 th October 2023
Designers Response				
Authority Response				

Distribution

Organisation	Contact	Copies
Ardent Consulting Engineers	David Howson	-

CONTENTS

Document Control Sheet	2
Contents	3
1 Introduction	4
2 Safety issues raised at previous Audits	5
3 Items raised at the Stage 1 Audit	6
4 Issues identified during the Stage 1 Audit that are outside the terms of reference	10
5 Auditors Statement	11

Appendix A..... List of drawings

Appendix B..... Comment Location Drawing

1 INTRODUCTION

1.1 This report describes a Stage 1 Road Safety Audit carried out on proposed Section 278 works associated with a proposed development in Ansty, West Sussex, comprising of:

- The provision of a three-arm roundabout on the A272 to serve the development.

The Audit was requested by the design organisation, Ardent Consulting Engineers, Crescent Court, High St, Billericay, CM12 9AQ on behalf of West Sussex County Council as the Highway Authority.

1.2 The Audit Team membership was as follows:

Martin Morris, PGD, MCIHT, MSoRSA – Audit Team Leader
Highways England Approved RSA Certificate of Competency

Bryan Shawyer B.Eng. (Hons), MSc, MCIHT, MSoRSA– Audit Team Member
Highways England Approved RSA Certificate of Competency

1.3 The audit was undertaken following the principles of GG 119, The Design Manual for Roads and Bridges. The documents available at the time of the report are detailed in Appendix A.

1.4 The Audit took place at the Gillingham offices of M&S Traffic during October 2023 and comprised an examination of the documents provided as listed in Appendix A. A joint site visit and inspection was undertaken on the 10th of October 2023 between 11:30 and 17:30 hours. Weather conditions at the time were fine and the road surfaces were dry. Traffic flows and free flow speeds were moderate. There were low pedestrian flows and no cyclist movements observed during the site visit.

1.5 The report has been compiled, only with regards to the safety implications for road users of the layout presented in the supplied drawings. It has not been examined or verified for compliance with any other standards or criteria. This safety audit does not perform any “Technical Check function on these proposals. It is assumed that the Project Sponsor is satisfied that such a Technical Check” has been successfully completed prior to requesting this safety audit.

1.6 No Departures from Standard, traffic flow or personal injury collision data was provided to the Audit Team.

1.7 All comments and recommendations are referenced to the detailed drawings and the locations have been detailed relating to the plans supplied with the audit brief, Appendix B.

2 ITEMS RAISED BY PREVIOUS AUDITS

2.1 No previous Road Safety Audits were supplied for assessment.

3 ITEMS RAISED AT THE STAGE 1 AUDIT

3.1 General

3.1.1 PROBLEM

Location: Approaches to the roundabout.

Summary: Insufficient construction details could lead to overshoot or rear end shunt collisions.

The proposals do not include the introduction of anti-skid surfacing or detail the Polished Stone Value (PSV) to be used on the approaches to the roundabout and surfacing as part of the scheme. Surfacing with an insufficient PSV could lead to overshoot or rear end shunt collisions.

RECOMMENDATION

It is recommended that high friction surfacing should be provided on all the approaches to the roundabout and that the PSV of all surfacing should be provided for assessment a Stage 2 Safety Audit.

3.1.2 PROBLEM

Location: Proposed roundabout.

Summary: Ponding of surface water could lead to loss of control collisions.

Kerblines are being amended as part of these proposals, where no details of carriageway drainage have been provided for assessment; ponding on the carriageway or water moving across the carriageway at junctions or bends could lead to loss of control collisions, particularly in wet / icy conditions.

RECOMMENDATION

It is recommended that drainage details should be provided at Stage 2 Safety Audit.

3.2 Local Alignment

3.2.1 PROBLEM

Location. Approaches to the proposed roundabout.

Stopping Sight Distances (SSD) have been provided for assessment and at 215m are acceptable for the current national speed limit. An insufficient SSD may increase the risk of junction related or shunt type collisions at the roundabout and so the 120m SSD, which is commensurate with a 40mph design speed, should only be incorporated if a reduced speed limit of 40mph is introduced.

RECOMMENDATION

It is recommended that the SSD should be commensurate with the design speeds.

3.2.2 PROBLEM

Location. Southwest bound approach to proposed roundabout.

Summary: Insufficient Stopping Sight Distance may increase the risk of junction related or shunt type collisions at the roundabout.

On the southwest bound approach to the roundabout SSDs have been provided for assessment. However, there is concern that the SSDs pass over non-highway land. Vegetation or landscaping features in these splays could restrict visibility, where insufficient visibility may increase the risk of junction related or shunt type collisions at the roundabout.

RECOMMENDATION

It is recommended that a suitable covenant should be arranged to ensure that the splay is not affected by planting or landscaping features.

3.2.3 PROBLEM

Location. Development arm of the proposed roundabout.

Summary: Insufficient Stopping Sight Distance may increase the risk of junction related or shunt type collisions at the roundabout.

On the northwestern bound approach to the roundabout no SSD has been provided for assessment. There is concern that the SSD could pass over non-highway land. Vegetation or landscaping features in this splay could restrict visibility, where insufficient visibility may increase the risk of junction related or shunt type collisions at the roundabout.

RECOMMENDATION

It is recommended that the SSD should be supplied for assessment and that they should be within the adoptable highway, or that a suitable covenant should be arranged to ensure that the splay is not affected by planting or landscaping features.

3.2.4 PROBLEM

Location: Proposed roundabout.

Summary: Lack of vertical profile information could lead to side impact collisions or loss of control collisions.

The proposed roundabout is located on the A272, where there is a fall from the southwest to the northeast. At this early stage no vertical alignment details were provided for assessment. There is concern that inappropriate vertical profiles could restrict visibility at the junction, which may lead to side impact collisions or loss of control collisions.

RECOMMENDATION

It is recommended that vertical alignment details should be provided for assessment at Stage 2 Safety Audit.

3.2.5 PROBLEM

Location: Proposed roundabout, all arms.

Summary: The exit layouts from the roundabout increase the risk of side swipe collisions, rear end shunts or loss of control collisions.

On all arms, the proposed exits from the roundabout are two lanes wide, narrowing to one lane over a short merge length. The layout encourages aggressive drivers to overtake a slower moving vehicle over a relatively short distance. There is concern that such overtaking manoeuvres could lead to side swipe collisions, rear end shunts or loss of control collisions, particularly as one of the of the merges is on a bend.

RECOMMENDATION

It is recommended that the exits from the roundabout should be restricted to one wide lane.

3.3 Junctions

3.3.1 PROBLEM

Location: Proposed roundabout.

Summary: Insufficient capacity could lead to rear end shunt or side impact collisions.

No details of expected flows and the capacity of the roundabout have been provided for assessment. Insufficient capacity could lead to congestion where excessive queuing at the roundabout could lead to driver frustration and the use of inappropriate gaps, further unbalanced flows could lead to entry problems on to the roundabout. This may lead to rear end shunt or side impact collisions.

RECOMMENDATION

It is recommended that the roundabout should operate without excessive queuing and with balanced flows and that an ARCADY or similar model should be provided for assessment.

3.3.2 PROBLEM

Location: Proposed roundabout, northeastern and development arms.

Summary: Low angle of entry may increase the risk of side impact collisions.

The angle of entry was provided for assessment, where for northeastern and development arms the angle of entry was less than twenty degrees. Low angles of entry could force drivers to look over their shoulders or use their mirrors to merge with circulating traffic, increasing the risk of side impact collisions.

RECOMMENDATION

It is recommended that the angle of entry should lie between 20° and 60°.

3.4 Non-Motorised User (NMU) Provision

3.4.1 No comment.

3.5 Road Signs, Carriageway Markings and Lighting

3.5.1 PROBLEM

Location: Proposed roundabout.

Summary: Insufficient street lighting could lead to loss of control collisions and side impact collisions during the hours of darkness.

At this early stage no details of street lighting have been provided for assessment. A lack of lighting could increase the risk of loss of control and side impact collisions at the roundabout during the hours of darkness.

RECOMMENDATION

It is recommended that street lighting should be checked with the Highway Authority's street lighting team and that a plan showing the light distribution should be provided for assessment at Stage 2 Safety Audit.

4 ISSUES IDENTIFIED DURING THE ROAD SAFETY AUDIT THAT ARE OUTSIDE THE TERMS OF REFERENCE

4.1 Safety issues identified during the audit and site inspection that are outside the Terms of Reference, but which the Audit Team wishes to draw to the attention of the Client Organisation, are set out in this section. It is to be understood that, in raising these issues, the Audit Team in no way warrant that a full review of the highway environment has been undertaken beyond that necessary to undertake the Audit as commissioned.

4.2 The Audit Team had no issues to raise within this section.

5 AUDITOR TEAM STATEMENT

5.1 We certify that this audit has been carried out following the principles of GG 119.

Audit Team Leader

Martin Morris
PGD, MCIHT, MSoRSA
Highways England Approved RSA Certificate of Competency

Signed:  Date: 13/10/2023

Audit Team Member

Bryan Shawyer
BEng (Hons), MSc, MCIHT, MSoRSA
Highways England Approved RSA Certificate of Competency

Signed:  Date: 13/10/2023

M & S Traffic

Aeolus House
32 Hamelin Road
Gillingham
Kent ME7 3EX



+44 (0) 1634 307 498



contact@mstraffic.co.uk



www.mstraffic.co.uk

APPENDIX A

List of Drawings and other information submitted for auditing:

Drawing Number	Title
2207280-004 C	Proposed Roundabout Western Access (A272)

Supporting documentation:

- Covering emails, Ardent Consulting Engineers.

APPENDIX B

Plan attached showing the locations of the problems identified as part of this audit (location numbers refer to paragraph numbers in the report).

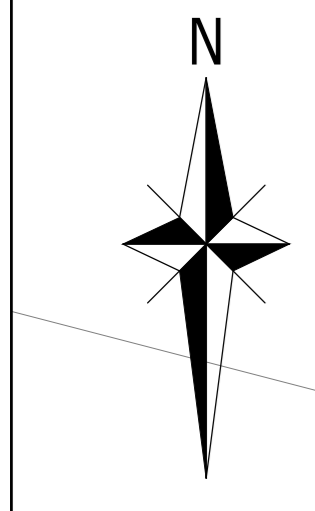
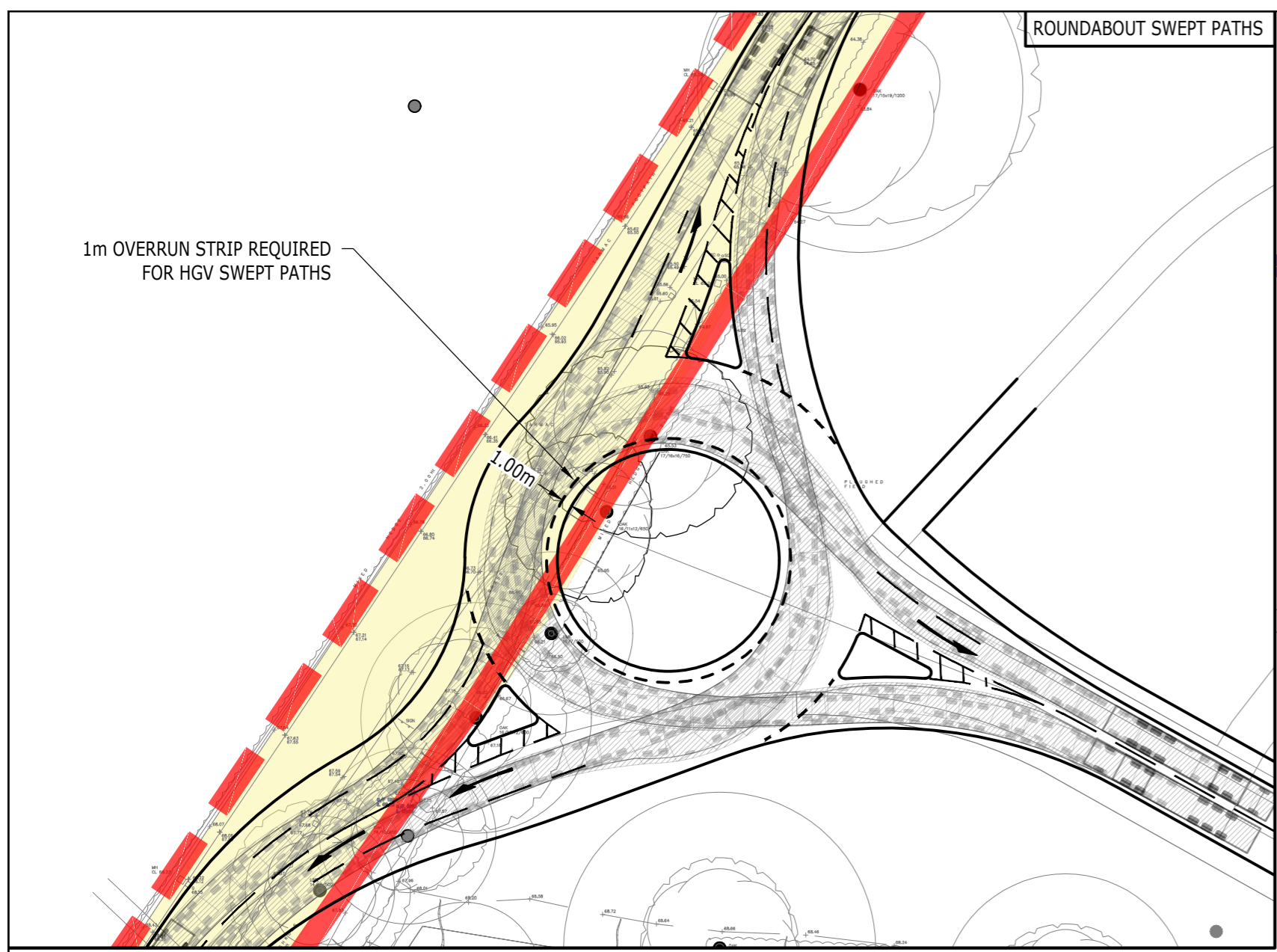
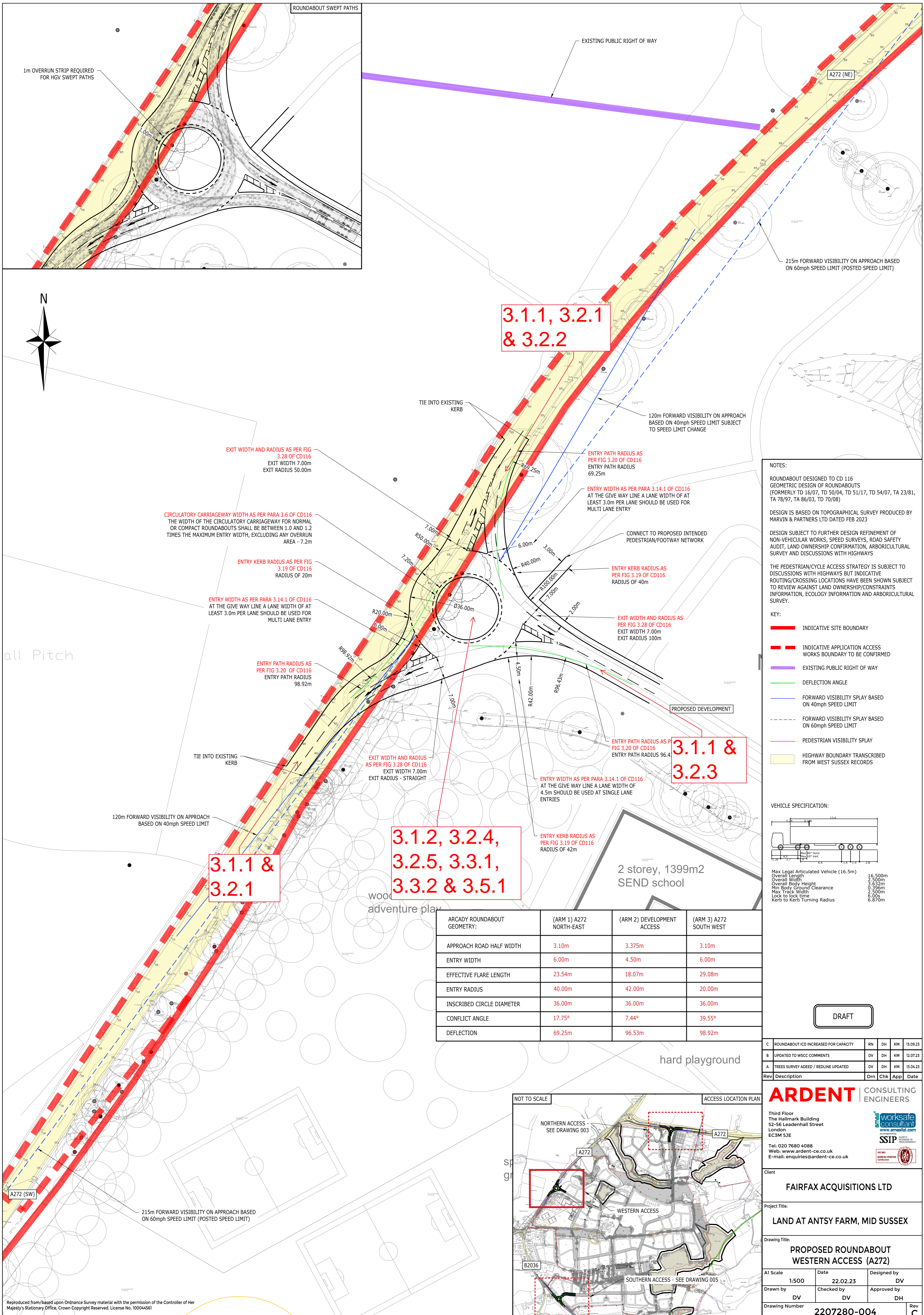

all Pitch

NOTES:
 ROUNDAABOUT DESIGNED TO CD 116
 GEOMETRIC DESIGN OF ROUNDAABOUTS
 (FORMERLY TD 16/07, TD 50/04, TD 51/17, TD 54/07, TA 23/81, TA 78/97, TA 86/03, TD 70/08)
 DESIGN IS BASED ON TOPOGRAPHICAL SURVEY PRODUCED BY MARVIN & PARTNERS LTD DATED FEB 2023
 DESIGN SUBJECT TO FURTHER DESIGN REFINEMENT OF NON-VEHICULAR WORKS, SPEED SURVEYS, ROAD SAFETY AUDIT, LAND OWNERSHIP CONFIRMATION, ARBORICULTURAL SURVEY AND DISCUSSIONS WITH HIGHWAYS
 THE PEDESTRIAN/CYCLE ACCESS STRATEGY IS SUBJECT TO DISCUSSIONS WITH HIGHWAYS BUT INDICATIVE ROUTING/CROSSING LOCATIONS HAVE BEEN SHOWN SUBJECT TO REVIEW AGAINST LAND OWNERSHIP/CONSTRAINTS INFORMATION, ECOLOGY INFORMATION AND ARBORICULTURAL SURVEY.

- KEY:**
- INDICATIVE SITE BOUNDARY
 - - - INDICATIVE APPLICATION ACCESS WORKS BOUNDARY TO BE CONFIRMED
 - EXISTING PUBLIC RIGHT OF WAY
 - DEFLECTION ANGLE
 - FORWARD VISIBILITY SPYLAZES BASED ON 40mph SPEED LIMIT
 - - - FORWARD VISIBILITY SPYLAZES BASED ON 60mph SPEED LIMIT
 - PEDESTRIAN VISIBILITY SPYLAZES
 - HIGHWAY BOUNDARY TRANSCRIBED FROM WEST SUSSEX RECORDS

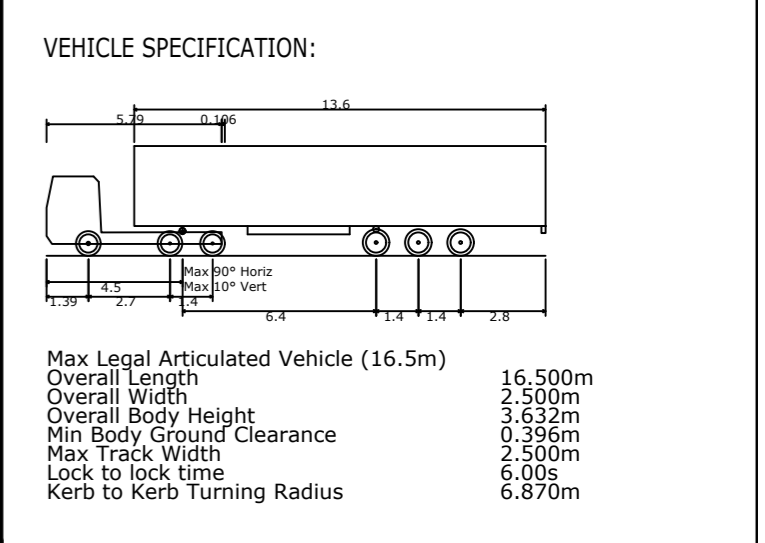

ARCADEY ROUNDAABOUT GEOMETRY:	(ARM 1) A272 NORTH-EAST	(ARM 2) DEVELOPMENT ACCESS	(ARM 3) A272 SOUTH WEST
APPROACH ROAD HALF WIDTH	3.10m	3.375m	3.10m
ENTRY WIDTH	6.00m	4.50m	6.00m
EFFECTIVE FLARE LENGTH	23.54m	18.07m	29.08m
ENTRY RADIUS	40.00m	42.00m	20.00m
INSCRIBED CIRCLE DIAMETER	36.00m	36.00m	36.00m
CONFLICT ANGLE	17.75°	7.44°	39.55°
DEFLECTION	69.25m	96.53m	98.92m

DRAFT

Rev	Description	Drn	Chk	App	Date
C	ROUNDAABOUT ICD INCREASED FOR CAPACITY	RN	DH	XM	13.09.23
B	UPDATED TO WSCC COMMENTS	DV	DH	XM	12.07.23
A	TREES SURVEY ADDED / REDLINE UPDATED	DV	DH	XM	13.04.23

ARDENT CONSULTING ENGINEERS

Third Floor
 The Hallmark Building
 52-56 Leadenhall Street
 London
 EC3M 5JE

Tel: 020 7680 4088
 Web: www.ardent-ce.co.uk
 E-mail: enquiries@ardent-ce.co.uk

Client: **FAIRFAX ACQUISITIONS LTD**

Project Title: **LAND AT ANTASY FARM, MID SUSSEX**

Drawing Title: **PROPOSED ROUNDAABOUT WESTERN ACCESS (A272)**

At Scale: 1:500	Date: 22.02.23	Designed by: DV
Drawn by: DV	Checked by: DV	Approved by: DH
Drawing Number: 2207280-004		Rev: C

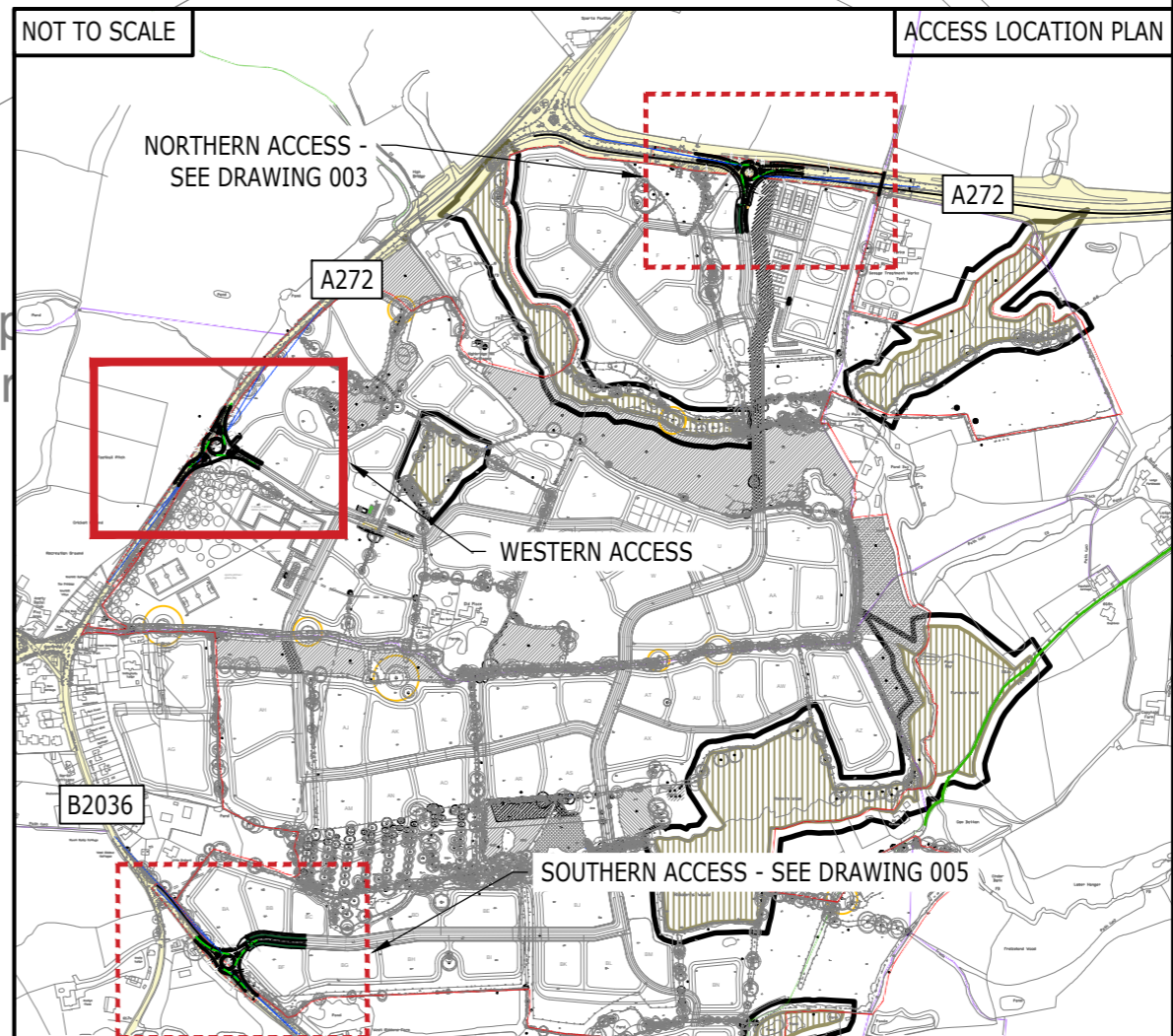

Reproduced from/based upon Ordnance Survey material with the permission of the Controller of Her Majesty's Stationary Office, Crown Copyright Reserved. License No. 100044561

Designers Response Appendix B

M&S Traffic Response

David Howson

From: martin.morris <martin.morris@mstraffic.co.uk>
Sent: 25 October 2023 08:15
To: David Howson; bryan.shawyer
Cc: Jamie Symington; Dan Vallance
Subject: RE: Ansty - Designers Response 2nd draft - Northern Access

EXTERNAL EMAIL: Do not click any links or open any attachments unless you trust the sender and know the content is safe.

Hi David

Many thanks for these our comments are as follows:

- 3.1.1 Noted and accepted.
- 3.1.2 Noted and accepted.
- 3.1.3 Noted.
- 3.1.4 Noted and accepted.
- 3.1.5 Noted and accepted.
- 3.1.6 Noted and accepted.
- 3.1.7 Noted and accepted.
- 3.2.1 Noted and accepted.
- 3.2.2 Noted and accepted.
- 3.2.3 Noted and accepted.
- 3.3.1 Noted and accepted.
- 3.5.1 Noted and accepted.
- 3.5.2 Noted and accepted.
- 3.5.3 Noted and accepted.

Martin

Martin Morris
Managing Director

M&S Traffic Ltd
Aeolus House, 32 Hamelin Road, Gillingham, Kent ME7 3EX

M: 07772 163843 T: 01634 307498

From: David Howson <dhowson@ardent-ce.co.uk>
Sent: Tuesday, October 24, 2023 5:36 PM
To: martin.morris <martin.morris@mstraffic.co.uk>; bryan.shawyer <bryan.shawyer@mstraffic.co.uk>
Cc: Jamie Symington <jsymington@ardent-ce.co.uk>; Dan Vallance <dvallance@ardent-ce.co.uk>
Subject: Ansty - Designers Response 2nd draft - Northern Access

Dear Martin,

Further to receipt of the Stage 1 RSA prepared by M&S Traffic, we have collated a Designers Response (DR) and in accordance with GG119 will be sending to WSCC Highways as the Overseeing Organisation in due course.

However, in the interim we thought it appropriate to send our draft DR for M&S feedback and comment that we have suitably addressed the points raised for RSA1.

Kind regards
David

David Howson
Associate



An Employee-Owned Company
Infrastructure | Transport Planning | Flood Risk | Acoustics | Air Quality

T | 01473 407321 E | dhowson@ardent-ce.co.uk
Suffolk Enterprise Centre | Felaw Maltings | 44 Felaw Street | Ipswich IP2 8SJ

London | Edinburgh | Essex | Kent | Midlands | South West | **Suffolk**



This e-mail is intended for the addressee(s) only. If, however you have received this e-mail in error, please delete all copies of it and any attachments, and treat the contents as confidential. We apologise for any inconvenience this may cause.
The views and opinions expressed in this e-mail message are those of the author and must not be assumed to be those of the Company.
This e-mail has been checked by anti-virus software. The Company accepts no liability for any damages related to receipt of this e-mail, howsoever caused.
Arden Consulting Engineers Ltd is registered in England, Company Number 05463029. Registered Office: Third Floor, The Hallmark Building, 52-56 Leadenhall Street, London EC3M 5JE. © Arden Consulting Engineers Limited

Designers Response Appendix C

ARCADY Output

Junctions 10
ARCADY 10 - Roundabout Module
Version: 10.0.4.1693 © Copyright TRL Software Limited, 2021
For sales and distribution information, program advice and maintenance, contact TRL Software: +44 (0)1344 379777 software@trl.co.uk trlsoftware.com
The users of this computer program for the solution of an engineering problem are in no way relieved of their responsibility for the correctness of the solution

Filename: Jct F - Northern Site Access.j10
Path: Y:\ARDENT PROJECTS\2207280 - Land at Ansty Farm, Mid Sussex\Transport\ARCADY
Report generation date: 27/09/2023 12:06:06

»2039 Do Something Isolated, AM
 »2039 Do Something Isolated, PM

Summary of junction performance

	AM			PM		
	Q (Veh)	Delay (s)	RFC	Q (Veh)	Delay (s)	RFC
2039 Do Something Isolated						
1 - A272 (E)	0.6	4.48	0.39	2.5	9.38	0.72
2 - Site Access 1	0.2	4.08	0.16	0.1	4.77	0.08
3 - A272 (W)	3.0	14.40	0.75	1.0	6.12	0.49

Values shown are the highest values encountered over all time segments. Delay is the maximum value of Av. delay per arriving vehicle.

File summary

File Description

Title	A272 / Site Access 1
Location	
Site number	
Date	27/04/2023
Version	
Status	
Identifier	
Client	
Jobnumber	
Enumerator	
Description	

Units

Distance units	Speed units	Traffic units input	Traffic units results	Flow units	Av. delay units	Total delay units	Rate of delay units
m	kph	Veh	Veh	perHour	s	-Hour	perHour

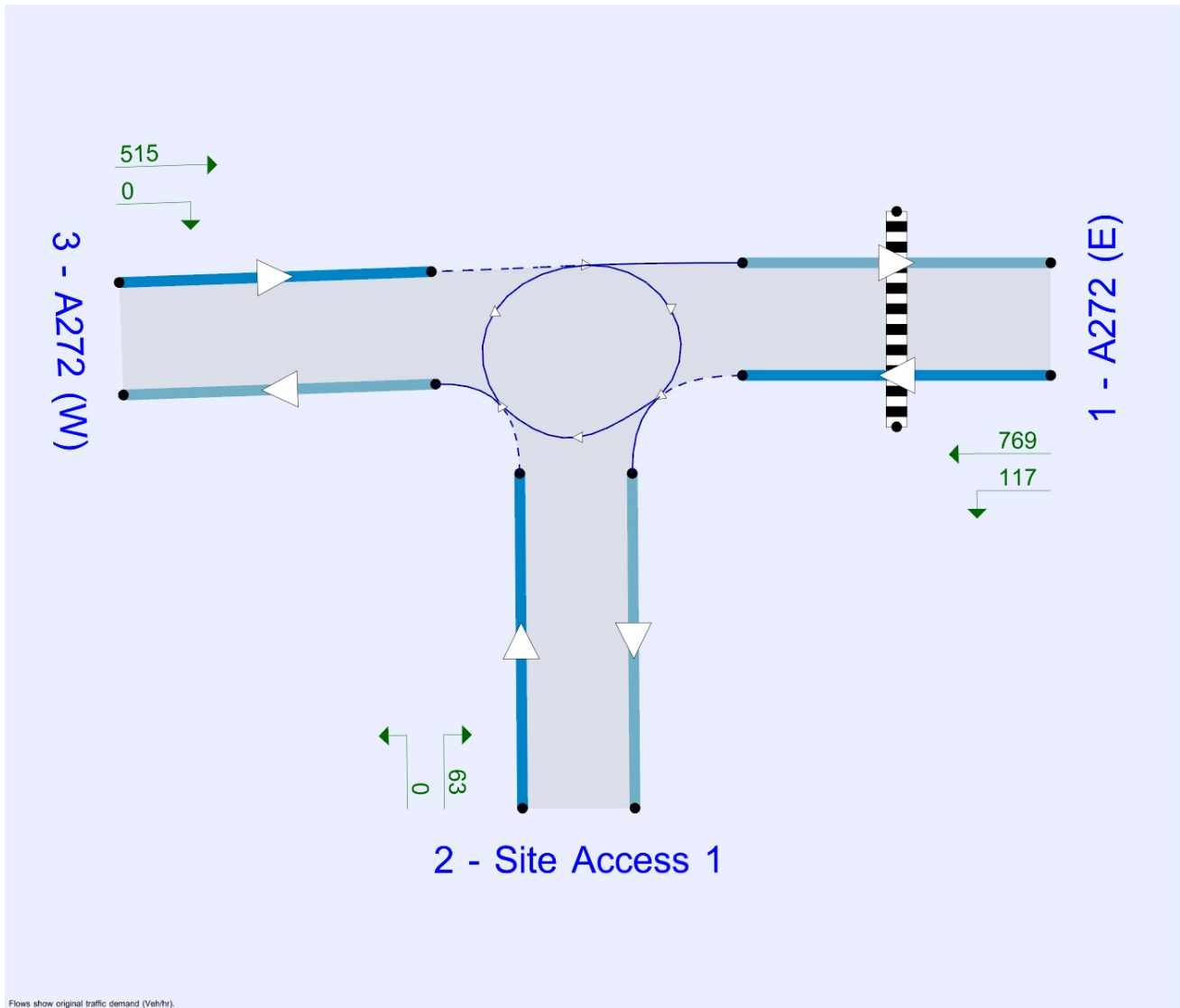

Flows show original traffic demand (Veh/hr).

The junction diagram reflects the last run of Junctions.

Analysis Options

Vehicle length (m)	Calculate Q Percentiles	Calculate detailed queueing delay	Show lane queues in feet / metres	Show all PICADY stream intercepts	Calculate residual capacity	RFC Threshold	Av. Delay threshold (s)	Q threshold (PCU)	Use iterations with HCM roundabouts	Max number of iterations for roundabouts
5.75						0.85	36.00	20.00		500

Demand Set Summary

ID	Scenario name	Time Period name	Traffic profile type	Start time (HH:mm)	Finish time (HH:mm)	Time segment length (min)	Run automatically
D1	2039 Do Something Isolated	AM	ONE HOUR	07:45	09:15	15	✓
D2	2039 Do Something Isolated	PM	ONE HOUR	16:45	18:15	15	✓

Analysis Set Details

ID	Include in report	Network flow scaling factor (%)	Network capacity scaling factor (%)
A1	✓	100.000	100.000

2039 Do Something Isolated, AM

Data Errors and Warnings

No errors or warnings

Junction Network

Junctions

Junction	Name	Junction type	Use circulating lanes	Arm order	Junction Delay (s)	Junction LOS
1	A272 / Site Access 1	Standard Roundabout		1, 2, 3	9.71	A

Junction Network

Driving side	Lighting	Network delay (s)	Network LOS
Left	Normal/unknown	9.71	A

Arms

Arms

Arm	Name	Description	No give-way line
1	A272 (E)		
2	Site Access 1		
3	A272 (W)		

Roundabout Geometry

Arm	V (m)	E (m)	I' (m)	R (m)	D (m)	PHI (deg)	Entry only	Exit only
1 - A272 (E)	3.65	4.50	13.5	40.0	30.0	26.0		
2 - Site Access 1	3.25	4.50	12.5	42.0	30.0	23.0		
3 - A272 (W)	3.50	4.50	4.5	15.0	30.0	31.0		

Zebra Crossings

Arm	VGAP (PCU)	Vehs queueing on exit (PCU)	Central Refuge	Crossing data type	Crossing length (m)	Crossing time (s)
1 - A272 (E)	3.00	3.00		Distance	7.30	5.21

Slope / Intercept / Capacity

Roundabout Slope and Intercept used in model

Arm	Final slope	Final intercept (PCU/hr)
1 - A272 (E)	0.602	1371
2 - Site Access 1	0.599	1335
3 - A272 (W)	0.552	1213

The slope and intercept shown above include any corrections and adjustments.

Traffic Demand

Demand Set Details

ID	Scenario name	Time Period name	Traffic profile type	Start time (HH:mm)	Finish time (HH:mm)	Time segment length (min)	Run automatically
D1	2039 Do Something Isolated	AM	ONE HOUR	07:45	09:15	15	✓

Vehicle mix varies over turn	Vehicle mix varies over entry	Vehicle mix source	PCU Factor for a HV (PCU)
✓	✓	HV Percentages	2.00

Demand overview (Traffic)

Arm	Linked arm	Profile type	Use O-D data	Av. Demand (Veh/hr)	Scaling Factor (%)
1 - A272 (E)		ONE HOUR	✓	462	100.000
2 - Site Access 1		ONE HOUR	✓	156	100.000
3 - A272 (W)		ONE HOUR	✓	690	100.000

Demand overview (Pedestrians)

Arm	Profile type	Av. Ped flow (Ped/hr)
1 - A272 (E)	[ONEHOUR]	100.00
2 - Site Access 1		
3 - A272 (W)		

Origin-Destination Data

Demand (Veh/hr)

From	To		
	1 - A272 (E)	2 - Site Access 1	3 - A272 (W)
1 - A272 (E)	0	56	406
2 - Site Access 1	156	0	0
3 - A272 (W)	690	0	0

Vehicle Mix

HV %s

From	To		
	1 - A272 (E)	2 - Site Access 1	3 - A272 (W)
1 - A272 (E)	0	0	5
2 - Site Access 1	0	0	0
3 - A272 (W)	5	0	0

Results

Results Summary for whole modelled period

Arm	Max RFC	Max Delay (s)	Max Q (Veh)	Max LOS	Av. Demand (Veh/hr)	Total Junction Arrivals (Veh)
1 - A272 (E)	0.39	4.48	0.6	A	424	636
2 - Site Access 1	0.16	4.08	0.2	A	143	215
3 - A272 (W)	0.75	14.40	3.0	B	633	950

Main Results for each time segment

07:45 - 08:00

Arm	Total Demand (Veh/hr)	Junction Arrivals (Veh)	Circulating flow (Veh/hr)	Ped demand (Ped/hr)	Capacity (Veh/hr)	RFC	Throughput (Veh/hr)	Throughput (exit) (Veh/hr)	Start queue (Veh)	End queue (Veh)	Delay (s)	Unsignalised level of service
1 - A272 (E)	348	87	0	75.29	1313	0.265	346	633	0.0	0.4	3.720	A
2 - Site Access 1	117	29	304		1144	0.103	117	42	0.0	0.1	3.504	A
3 - A272 (W)	519	130	117		1085	0.479	516	304	0.0	0.9	6.324	A

08:00 - 08:15

Arm	Total Demand (Veh/hr)	Junction Arrivals (Veh)	Circulating flow (Veh/hr)	Ped demand (Ped/hr)	Capacity (Veh/hr)	RFC	Throughput (Veh/hr)	Throughput (exit) (Veh/hr)	Start queue (Veh)	End queue (Veh)	Delay (s)	Unsignalised level of service
1 - A272 (E)	415	104	0	89.90	1313	0.316	415	759	0.4	0.5	4.007	A
2 - Site Access 1	140	35	365		1106	0.127	140	50	0.1	0.1	3.726	A
3 - A272 (W)	620	155	140		1061	0.585	618	365	0.9	1.4	8.097	A

08:15 - 08:30

Arm	Total Demand (Veh/hr)	Junction Arrivals (Veh)	Circulating flow (Veh/hr)	Ped demand (Ped/hr)	Capacity (Veh/hr)	RFC	Throughput (Veh/hr)	Throughput (exit) (Veh/hr)	Start queue (Veh)	End queue (Veh)	Delay (s)	Unsignalised level of service
1 - A272 (E)	509	127	0	110.10	1312	0.388	508	925	0.5	0.6	4.471	A
2 - Site Access 1	172	43	446		1055	0.163	172	62	0.1	0.2	4.076	A
3 - A272 (W)	760	190	172		1010	0.752	754	446	1.4	2.9	13.730	B

08:30 - 08:45

Arm	Total Demand (Veh/hr)	Junction Arrivals (Veh)	Circulating flow (Veh/hr)	Ped demand (Ped/hr)	Capacity (Veh/hr)	RFC	Throughput (Veh/hr)	Throughput (exit) (Veh/hr)	Start queue (Veh)	End queue (Veh)	Delay (s)	Unsignalised level of service
1 - A272 (E)	509	127	0	110.10	1312	0.388	509	931	0.6	0.6	4.478	A
2 - Site Access 1	172	43	447		1054	0.163	172	62	0.2	0.2	4.079	A
3 - A272 (W)	760	190	172		1008	0.753	759	447	2.9	3.0	14.401	B

08:45 - 09:00

Arm	Total Demand (Veh/hr)	Junction Arrivals (Veh)	Circulating flow (Veh/hr)	Ped demand (Ped/hr)	Capacity (Veh/hr)	RFC	Throughput (Veh/hr)	Throughput (exit) (Veh/hr)	Start queue (Veh)	End queue (Veh)	Delay (s)	Unsignalised level of service
1 - A272 (E)	415	104	0	89.90	1313	0.316	416	767	0.6	0.5	4.016	A
2 - Site Access 1	140	35	366		1105	0.127	140	50	0.2	0.1	3.730	A
3 - A272 (W)	620	155	140		1060	0.585	626	366	3.0	1.4	8.417	A

09:00 - 09:15

Arm	Total Demand (Veh/hr)	Junction Arrivals (Veh)	Circulating flow (Veh/hr)	Ped demand (Ped/hr)	Capacity (Veh/hr)	RFC	Throughput (Veh/hr)	Throughput (exit) (Veh/hr)	Start queue (Veh)	End queue (Veh)	Delay (s)	Unsignalised level of service
1 - A272 (E)	348	87	0	75.29	1313	0.265	348	639	0.5	0.4	3.734	A
2 - Site Access 1	117	29	306		1143	0.103	118	42	0.1	0.1	3.511	A
3 - A272 (W)	519	130	118		1084	0.479	522	306	1.4	0.9	6.417	A

2039 Do Something Isolated, PM

Data Errors and Warnings

No errors or warnings

Junction Network

Junctions

Junction	Name	Junction type	Use circulating lanes	Arm order	Junction Delay (s)	Junction LOS
1	A272 / Site Access 1	Standard Roundabout		1, 2, 3	8.04	A

Junction Network

Driving side	Lighting	Network delay (s)	Network LOS
Left	Normal/unknown	8.04	A

Traffic Demand

Demand Set Details

ID	Scenario name	Time Period name	Traffic profile type	Start time (HH:mm)	Finish time (HH:mm)	Time segment length (min)	Run automatically
D2	2039 Do Something Isolated	PM	ONE HOUR	16:45	18:15	15	✓

Vehicle mix varies over turn	Vehicle mix varies over entry	Vehicle mix source	PCU Factor for a HV (PCU)
✓	✓	HV Percentages	2.00

Demand overview (Traffic)

Arm	Linked arm	Profile type	Use O-D data	Av. Demand (Veh/hr)	Scaling Factor (%)
1 - A272 (E)		ONE HOUR	✓	886	100.000
2 - Site Access 1		ONE HOUR	✓	63	100.000
3 - A272 (W)		ONE HOUR	✓	515	100.000

Demand overview (Pedestrians)

Arm	Profile type	Av. Ped flow (Ped/hr)
1 - A272 (E)	[ONEHOUR]	100.00
2 - Site Access 1		
3 - A272 (W)		

Origin-Destination Data

Demand (Veh/hr)

		To		
		1 - A272 (E)	2 - Site Access 1	3 - A272 (W)
From	1 - A272 (E)	0	117	769
	2 - Site Access 1	63	0	0
	3 - A272 (W)	515	0	0

Vehicle Mix

HV %s

From	To		
	1 - A272 (E)	2 - Site Access 1	3 - A272 (W)
1 - A272 (E)	0	0	1
2 - Site Access 1	0	0	0
3 - A272 (W)	1	0	0

Results

Results Summary for whole modelled period

Arm	Max RFC	Max Delay (s)	Max Q (Veh)	Max LOS	Av. Demand (Veh/hr)	Total Junction Arrivals (Veh)
1 - A272 (E)	0.72	9.38	2.5	A	813	1220
2 - Site Access 1	0.08	4.77	0.1	A	58	87
3 - A272 (W)	0.49	6.12	1.0	A	473	709

Main Results for each time segment
16:45 - 17:00

Arm	Total Demand (Veh/hr)	Junction Arrivals (Veh)	Circulating flow (Veh/hr)	Ped demand (Ped/hr)	Capacity (Veh/hr)	RFC	Throughput (Veh/hr)	Throughput (exit) (Veh/hr)	Start queue (Veh)	End queue (Veh)	Delay (s)	Unsignalised level of service
1 - A272 (E)	667	167	0	75.29	1359	0.491	663	433	0.0	1.0	5.147	A
2 - Site Access 1	47	12	576		987	0.048	47	88	0.0	0.1	3.830	A
3 - A272 (W)	388	97	47		1174	0.330	386	576	0.0	0.5	4.555	A

17:00 - 17:15

Arm	Total Demand (Veh/hr)	Junction Arrivals (Veh)	Circulating flow (Veh/hr)	Ped demand (Ped/hr)	Capacity (Veh/hr)	RFC	Throughput (Veh/hr)	Throughput (exit) (Veh/hr)	Start queue (Veh)	End queue (Veh)	Delay (s)	Unsignalised level of service
1 - A272 (E)	796	199	0	89.90	1359	0.586	795	519	1.0	1.4	6.361	A
2 - Site Access 1	57	14	690		918	0.062	57	105	0.1	0.1	4.178	A
3 - A272 (W)	463	116	57		1167	0.397	462	690	0.5	0.7	5.101	A

17:15 - 17:30

Arm	Total Demand (Veh/hr)	Junction Arrivals (Veh)	Circulating flow (Veh/hr)	Ped demand (Ped/hr)	Capacity (Veh/hr)	RFC	Throughput (Veh/hr)	Throughput (exit) (Veh/hr)	Start queue (Veh)	End queue (Veh)	Delay (s)	Unsignalised level of service
1 - A272 (E)	976	244	0	110.10	1359	0.718	971	635	1.4	2.5	9.193	A
2 - Site Access 1	69	17	843		825	0.084	69	128	0.1	0.1	4.761	A
3 - A272 (W)	567	142	69		1156	0.491	566	843	0.7	1.0	6.090	A

17:30 - 17:45

Arm	Total Demand (Veh/hr)	Junction Arrivals (Veh)	Circulating flow (Veh/hr)	Ped demand (Ped/hr)	Capacity (Veh/hr)	RFC	Throughput (Veh/hr)	Throughput (exit) (Veh/hr)	Start queue (Veh)	End queue (Veh)	Delay (s)	Unsignalised level of service
1 - A272 (E)	976	244	0	110.10	1359	0.718	975	636	2.5	2.5	9.384	A
2 - Site Access 1	69	17	847		823	0.084	69	129	0.1	0.1	4.774	A
3 - A272 (W)	567	142	69		1156	0.491	567	847	1.0	1.0	6.116	A

17:45 - 18:00

Arm	Total Demand (Veh/hr)	Junction Arrivals (Veh)	Circulating flow (Veh/hr)	Ped demand (Ped/hr)	Capacity (Veh/hr)	RFC	Throughput (Veh/hr)	Throughput (exit) (Veh/hr)	Start queue (Veh)	End queue (Veh)	Delay (s)	Unsignalised level of service
1 - A272 (E)	796	199	0	89.90	1359	0.586	801	521	2.5	1.4	6.500	A
2 - Site Access 1	57	14	695		915	0.062	57	106	0.1	0.1	4.195	A
3 - A272 (W)	463	116	57		1167	0.397	464	695	1.0	0.7	5.129	A

18:00 - 18:15

Arm	Total Demand (Veh/hr)	Junction Arrivals (Veh)	Circulating flow (Veh/hr)	Ped demand (Ped/hr)	Capacity (Veh/hr)	RFC	Throughput (Veh/hr)	Throughput (exit) (Veh/hr)	Start queue (Veh)	End queue (Veh)	Delay (s)	Unsignalised level of service
1 - A272 (E)	667	167	0	75.29	1359	0.491	669	436	1.4	1.0	5.232	A
2 - Site Access 1	47	12	581		984	0.048	47	88	0.1	0.1	3.845	A
3 - A272 (W)	388	97	47		1174	0.330	388	581	0.7	0.5	4.587	A