

●	1 Bed Flat	A - Affordable x2
●	2 Bed Flat	A - Affordable x4
●	2 Bed House	
●	3 Bed House	A - Affordable x3
●	4 Bed House	
TOTAL	28 DWELLINGS	9 AFFORDABLE 11 MARKET

Minimum 2 parking spaces per 2 bed dwelling
(excluding garages / carports)
4 visitor parking space

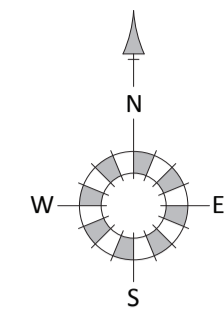

0 10m 20m

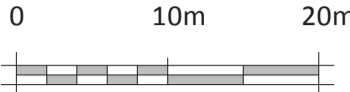

KEY

- Site boundary
- ➔ Site access
- T.H. Turning Head



Feasibility Site Layout
Land at Hurstwood Lane, Haywards Heath

21135 / SK18

Scale 1:500 @ A2 October 2025